

Contents

1 . About Product	1
2 . System configuration.....	2
3 . Installation.....	3
3.1 C2 installation	3
3.2 Fingerprint Machine installation.....	5
3.3 C2 connection with fingerprint machine	5
4. View of C2 panel.....	9
4. 1 Description for each terminal and port.....	12
4.1.1 Input and output port to control lock.....	12
4.1.2 RS232/ RS485 export port	17
4.1.4 RJ45 out socket	18
4.1.5 Alarm relay out port (JX1)	19
4.1.6 Door Bell (J11).....	20
4.1.7 Reset button (Reset)	21
4.1.8 Clear button (Default)	21
4.2. Product Special	22
5 . User Guide.....	25
6 . Troubleshooting.....	26

www.huellasdigitales.com.mx

1. About Product

C2 communication controller is critical equipment to new generation fingerprint Access Control System, which consist with the front-end fingerprint machine, communication controller, electrical –lock, door sensor, exit-button, computer and software etc.

Each control unit mate with front–end fingerprint machine and exit door button, the front end fingerprint machine performs verification to authenticate user himself. the background communication controller control the corresponding electrical lock, between the controller and fingerprint machine connection are created by RS232, boost up the system security. through standard RS232/RS485, TCP/IP communication way provided by the C2 communication controller, by means of these communication way the front fingerprint machine can connect with PC or created controlled network., C2 accept this order which is send by the fingerprint machine to switch the communication way of C2 communication controller, andC2 controller is able to supply the power through its power provided function, simply system and equipment provided.

2. System configuration



3. Installation

3.1 C2 installation

Volume and installation hole distance

- ◆ Externality volume : 117mm×98mm×40mm
- ◆ Installation hole distance: 56MM

Installation Guide:

Determine the position of nail on the wall, the controller should be mount on the inter wall of the door, after the position is determined, you can hammer two nail in the wall. Put the box on the wall. Use 8 core shield wire to connect the fingerprint machine and C2 controller, depend on the position of between the door sensor and release button that is far or not, select the diameter more than 0.8mm cable to connect.

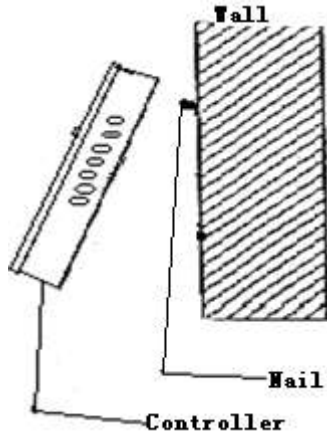

www.huellasdigitales.com.mx

3.2 Fingerprint Machine installation

Determine the position of mounting plate on the wall. The fingerprint machine should be mounted on the wall of the approximately 1400mm from the ground to the unit bottom. After the position is determined, attach the installation template on the wall where you want to mount fingerprint machine, according to this picture may mark out the hole position

You could drill four holes for fixing screw, these two hole should be on the same horizontal line :

- 1) If the fingerprint machine has a mounting plate, use the screw to fix mounting plate on the wall, then tie this fingerprint machine on the mounting plate.
- 2) Confirm all connection plugs correctly.
- 3) Align back Iron-plate of fingerprint machine body to mounting plate properly.
- 4) Turn and tie up the sew bottom.
- 5) After installation, please make sure the fingerprint machine is reliable, fasten, not loosed.

3.3 C2 connection with fingerprint machine

Through the data cable may create a connection between the fingerprint machine and C2 communication controller, like as following illustration.

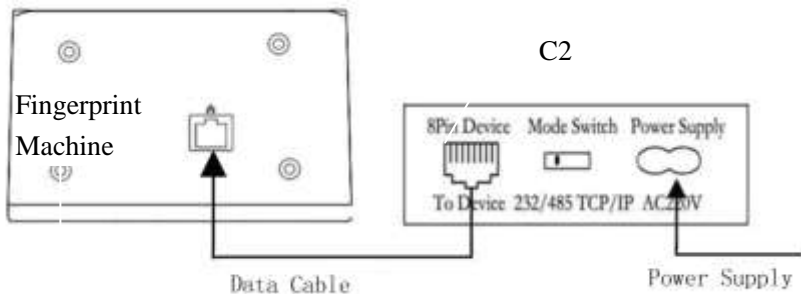

Each C2 controller and fingerprint machine has a ID to identify each another, you can set C2 correlation parameter through the fingerprint machine, and C2 also can monitor the fingerprint machine work, if the abnormal state occur, the C2 communication controller will respond to the trouble, each control unit not only may independently run, but also create network by may net

Note:: each fingerprint machine may bind more than one C2 communication controller which has not binding ID, but the C2 communication controller don't accept any fingerprint machine except one fingerprint machine until you press clear button

How to the Front –end fingerprint machine input signal into C2 controller

- ◆ RS232 , Baud rate 9600
- ◆ The most length to the distance between front-end machine and controller 10 meter.
- ◆ The commend length to the distance between front-end

machine and controller no than 3 meter

The binding ID between the fingerprint machine and C2

- ◆ Binding function , the front fingerprint machine and C2 communication can realize the Binding function, after binding , the other fingerprint is unable to communicate with this C2 until the Binding ID is eliminated by hand to push button.
- ◆ You use it at first time, the front–end fingerprint machine send one and only the binding ID to C2 controller.
- ◆ If it fails to connect, the following prompt message will appear

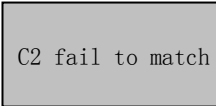

C2 fail to match

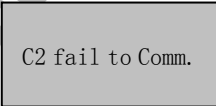

C2 fail to Comm.

It separately indicate to fail to match between C2 communication controller and fingerprint machine,. The communication C2 communication controller and fingerprint machine between is failure.

If somebody with hostility object wants to detect the binding ID, C2 will be invalid, and its built-in buzzer will send a urgent tweet “do”, at same time send signal to trigger warner

Each other Monitor work

- ◆ Monitor front-end fingerprint machine, if the front –end fingerprint machine does not communicate with C2 communication controller within 30 sec. thus the fingerprint machine is thought as it in abnormity state, at this time the C2 communication controller will restart the front–end fingerprint machine.

-
- ◆ The front-end fingerprint machine query C2 communication controller state per 10 second, at same time send signal to C2 communication controller for telling its state.
 - ◆ C2 send the information of the door sensor and release button to the fingerprint machine.

If the C2 monitor the front fingerprint machine, and find the communication overtime, C2 built-in buzzer will send a tweet “do” per 5 second. at same time send signal to trigger warner.

Set C2 option in the front-end fingerprint machine:

Push the menu key of the fingerprint machine -> Option-> Acc opts.

- ◆ How long time dose the lock to be controlled -- Lock
- ◆ How long time does check the door sensor to be delayed
-> Desen.Delay
- ◆ Relive alarm
- ◆ C2 watch dog , the default time 30 sec.(unchanged)

How long time the alarm cry, the default 10 sec. (unchanged)

4. View of C2 panel

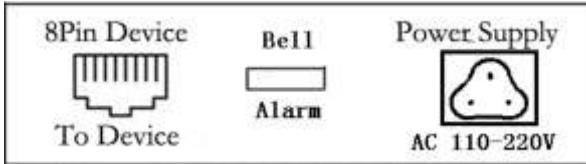

Left : RJ45 jack. Use only the manufacturer provided Data Cable approved for use with this equipment. This accepts a plug of Data Cable at one end and attaches to fingerprint machine at the other.

Center : This is a Socket that extends the peripheral alarm and door bell.

Right : Power supply socket, AC220 V in

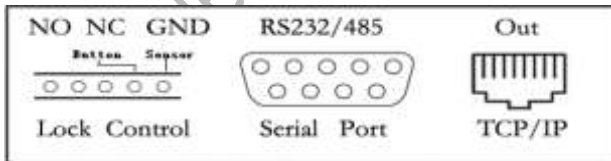

Left : The terminal for lock, door sensor, release button.

Center : RS232/485 serial port, here is RS 232/RS485 cable outlet and attaché to PC serial port.

Right : Network RJ45connector, that accepts a plug at one end and

connect switcher or directly connect PC

www.huellasdigitales.com.mx

Like as above picture illustrate, there are two buttons on the cooler hole of C2 communication, that are reset button and Restore Default button.

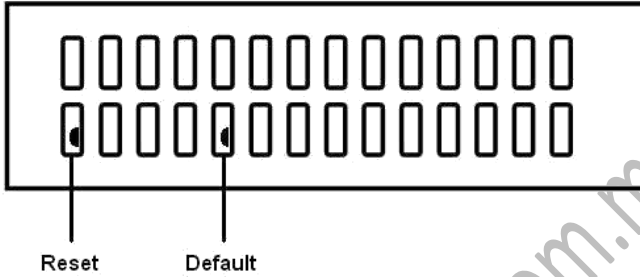

4. 1 Description for each terminal and port

Caution: Do not attempt to open C2 box cover yourself unless you are a trained service technician.

4.1.1 Input and output port to control lock

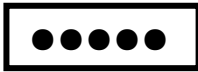

The terminal from the left to right are NC , GND, NO, Button, Sensor

The lock connect with NC, GND, NO terminal

Normally close (NC), under normal state the equipment keep up closed, if force the equipment open, the circuit cut off, bring out the state change.

Normally Open (NO), under normally state the circuit is cut off, if force the equipment open, the circuit will be closed, produce a state change.

Power Ground (GND), Current loop ground

Input terminal of door sensor (Sensor , GND) the input port of door sensor accepts the signal which come from normally closed contact to detect the door opening and closing state, when the door is in closed, the contact keep in closed state, if the door is opened by someone , the circuit break, thus bring out state change. If this door is opened by unauthorized user or opening time is too long, the controller will send alarm

Input terminal of release door button(Button , GND)The input port of release door button accepts the signal which come from normally opened contact to indicate that somebody want to go out, the input equipment such as “ action detector”, “ press sensitivity floor board” or exit-door button all serve as source to send signal , if nobody send out request to want to go out, the input keep disconnection , if somebody want to go out, they trigger release door button, the circuit is closed. Produce state change, the controller responded to the request, unlock and permit door serve as pass way.

Note : the process of performance to unlock door is control by relay, when you install door lock, there are two thing you must think about, -- safety and security , in other words, do you want which result that is if lose control of this door, the door is still in safety—‘lost control but safety’ or if lose control of this door, the door still is security--- “ lost control but security”

“lost control but safety” is that the power supply cut off (maybe the power supply is cut or the controller lose control of itself, the door will be open automatically, and permit everybody freely to pass in and out, the door is not ability to be closed until the system power on, these type of doors are installed in the protective area which ensure everybody is able to pass in and out. One representative application of “ lost control but safety” is to use electromagnetism lock, under normal power supply, the door is controlled by the controller, once the power supply break off, the electromagnetism lock will lose magnetism and does not take effect, the door become a pass way

“Lost control but security” is that the power supply cut off, the door

will be locked automatically, do not permit external personal to come in, but permit internal personal go out, the door is not to be unlocked until the system power supply is in gear. Make sure that the door of “lost control but security” will be installed in the area which needs to be protected through fair and foul. One representative application of “lost control but security” is to use electrical lock, if the power supply break off, the external personal is not able to open the door, but the internal person can open the by manual operation.

Following figure illustrate normally closed and normally opened join sketch maps

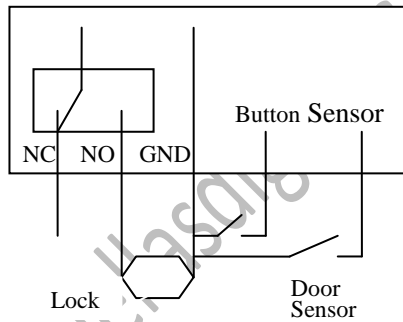

Unlock by power on

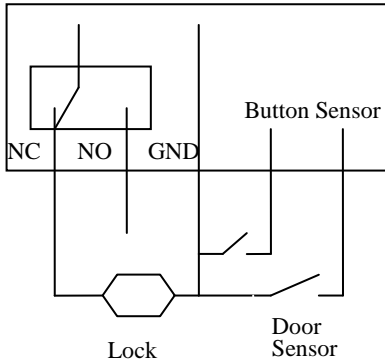

Unlock by power off

In the following three cases, we recommend that fingerprint machine and lock are powered separately.

- ◆ The working voltage of the lock is DC12V, but the current is difference.
- ◆ The lock voltage is not DC12V.
- ◆ The distance between lock and fingerprint machine is too far

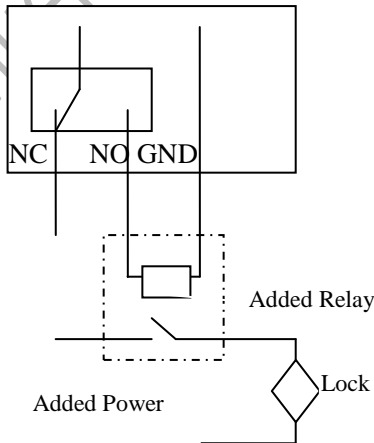

Separate power. Unlock by power on

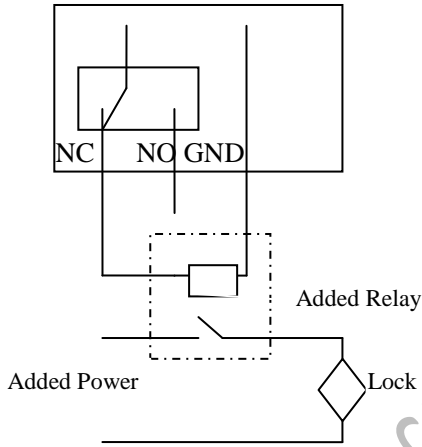

Separate power. Unlock by power off

4.1.2 RS232/ RS485 export port (unable to send two type of signal at some time)

Each pin saves as following description

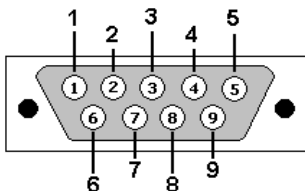

RS232

2---- RTX ; 3---TX ; 5— (GND) ; Rest pin is spare

RS485

4 - 485A + ; 5 - GND ; 7 - 485B - ; Rest pin is spare

4.1.3 RJ45 in socket (To connect with a front –end fingerprint machine)

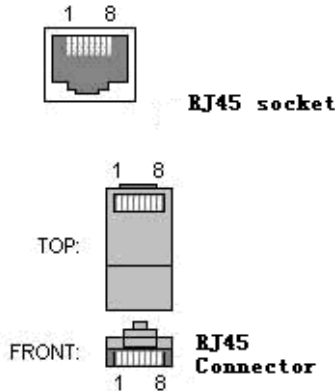

Standard RJ45 PIN number							
1	2	3	4	5	6	7	8
RJ45-1	RJ45-2	RJ45-3	RXD1	GND	RJ45-6	TXD1	+12V
RS485 A	RS485 B	RXD2	WD0	GND	TXD2	WD1	+12V

Note: 1) RXD1, TXD1 realize the RS232 communication between the fingerprint and C2 controller.

2) RXD2, TXD2 realize the RS232 communication between the fingerprint and PC

4.1.4 RJ45 out socket (To connect with a compute or switcher)

Standard RJ45 PIN number							
1	2	3	4	5	6	7	8
TX+	TX-	RX+			RX-		

If you want to connect a doorbell and warner, must open the cover of C2, and find following illustration position JX1 and J11

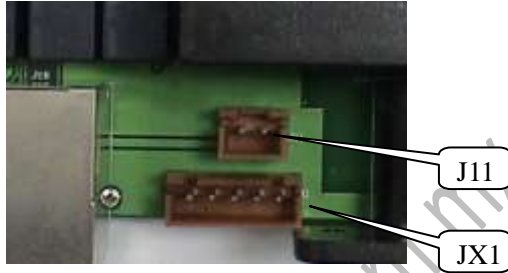

4. 1. 5 Alarm relay out port (JX1)

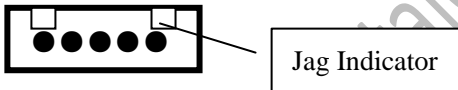

The pins from left to right are NC (normally closed), COM (common power supply), NO (normally open), +12VDC (power supply). Which outlet wire is provided by along with the C2 communication controller.

To perform the process of sending alarm is controlled by the relay of controller, once power on, the state of relay will change to trigger alarm

To join peripheral power supply way, please reference the joined lock by

Separate power

Notice : If you want install the alarm in the out-door, you must use peripheral power supply, if you ignore it, in no event shall manufacturer be liable for any lose arising out of user C2 power

Following figure illustrate that the alarm is in normally closed and

normally opened

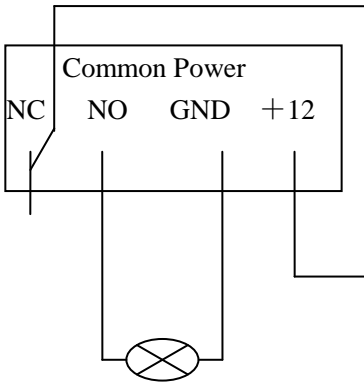

Normally open alarm

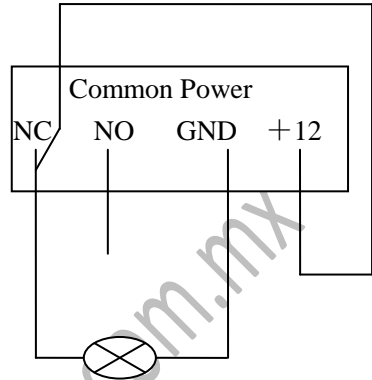

Normally close alarm

4. 1. 6 Door Bell (J11)



The pin from left to right are positive and negative of the power supply, the bell ring is controlled by replay output.

Notice: The doorbell governed by the special power supply request, Use only original manufactory provided wireless doorbell, doorbell approved for use with this C2. The doorbell power request is 12V, < 200mA.

4.1.7 Reset button (Reset)

If the system failure occur, the fingerprint machine break down, if you may push this button to restart C2 communication controller and front fingerprint to restart default setup

4.1.8 Clear button (Default)

Push this clear button; you may clear the binding ID for between C2 communication controller and front-end fingerprint machine.

4. 2. Product Special

Network Communication

- ◆ One standard RS232/485 or TCP/IP communication input port.
- ◆ One standard TCP/IP communication output port.
- ◆ One standard female DB9 connector, which send RS232 or RS485 signal.
- ◆ Via the front-end fingerprint machine realize the function to switch the communication.

Access Control

- ◆ One Door and one way.
- ◆ Opened door hour (1-5 second ability to adjust).
- ◆ Unlocked hour (1-5 second, ability to adjust).
- ◆ Electrical lock : Ability to connect several of normal opening lock, normal opening electrical drop bolt and electrical lock and electromagnetism lock.

Input and output terminal

- ◆ One relay output to control lock, normal open (NO), normal close (NC).
- ◆ One relay output to control alarm Normal open (NO), Normal close (NC).
- ◆ One terminal for door bell output.
- ◆ One standard terminal for door sensor input.
- ◆ One standard terminal for release button input.

DIP switch

- ◆ Set the number of DIP Switch to select input way of front-end fingerprint machine (Now, only RS2320).

Function button

- ◆ One Reset button.
- ◆ One restore default button.

Multi-alarm

- ◆ Opened door overtime.
- ◆ Anti- dismantles the front-end fingerprint machine.
- ◆ Duress to enter.
- ◆ Overtime for C2 connection with fingerprint machine.

Trouble proof:

- ◆ When the C2 communication controller has unlocked, if the communication between C2 and fingerprint machine occur failed, the lock still keep close.
- ◆ When the C2 communication controller give a warning, if fail to connect with fingerprint machine and C2 communication controller, the C2 communication will keep alarm state.
- ◆ If the C2 communication breaks down push its reset key, the C2 communication box will restart.
- ◆ If the front-end fingerprint machine trouble occur , push its reset key, the C2 communication controller and the fingerprint machine will restart together.
- ◆ If the front-end fingerprint machine breaks down, restore the machine through following routine, use an tool which diameter is no more than 2MM plug into reset hole of the fingerprint machine, this routine the time is not over 2 second, thus C2 will

restart along with the front –end fingerprint machine.

Power input and output

- ◆ Power Supply AC 220V.
- ◆ Fingerprint Machine Power Supply 12V .
- ◆ Alarm Current output 12V. <0.5A.
- ◆ Lock relay output 12V. <1.0A.

www.huellasdigitales.com.mx

5. User Guide

After installing the device, pursuant illustration to join the controller and peripheral equipment, be sure the wiring is correct, if it is not need to install the door sensor, please set the Door sensor option as “NO” in the front-end fingerprint machine, avoid the software always alarming. After system power is on. Examine and check the fingerprint machine whether work properly or not, use the Access Control Software to test each controlling unit, if the Access Control software shows that this system is clear and local work already finish.

Before using this Access Control System, user must download user information to corresponding controlling unit, refer to Access Control Software User Guide, and setup each controlling Unit option-- Time Zone, User Group. Group Time Zone, after assigning privilege to each the Door and in-out each door, Initialize the Access Control System in the software, after initialization is successful, so this Access Control system basic preparative work finish (more detail See Access Control Software).

6. Troubleshooting

Case	check content	Deal with way
Power indicator is failure	Check power wire, whether it become loose or on power	Join wire well again or change the power switch.
After User to be authenticated, fail to unlock	Check user's privilege	Check Time Zone, Group Time Zone, reset the user privilege.
Fail to communicate with fingerprint machine.	Power off, check whether the communication cable connection is firm or not. Check the DIP switch setup in the C2 or fingerprint machine. Check whether clear Binding ID or not	Connect cable well again; reset the DIP in properly position. Note: the different fingerprint has different DIP number
The relay fail to act after user to be authenticate	Check connection cable and relay	Renew relay

Note: information in this document is subject to change without notice